



- Single phase input: 115, 220, 230, 415, 480 VAC, 50 / 60 Hz cycles
- Three phase input: 208, 380, 415, 480 VAC, 50/ 60 Hz cycles
- Output current range: 3A-75A DC
- Output voltage range: 12V-100V DC
- Control: Tap switch, link bar
- Over load and short circuit protection: MCB and high speed HRC secondary fuses
- Meters: 2% accuracy analog voltmeters and ammeters. Options include potential meter, LED and LCD displays
- Standard enclosure: 2 mm min thick carbon steel housing. Options include hot dipped galvanized, stainless steel, aluminium, GRP
- IP Rating: conforming to IP55 up to IP65
- Operating ambient: Continuously rated up to 55° C
- Optional Remote monitoring: 4-20mA transducer, RS485 digital via microcontroller, potential free contacts

CTS Transformer Rectifiers are custom built to meet the diverse standards and specifications of the cathodic protection industry across the globe. CTS can provide different types of Transformer Rectifiers such as tap set, variac, and phase control.

Each type of Transformer Rectifier can be provided with different types of cooling, enclosure etc.

This data sheet covers the specific details for tap set control air cooled units.

Enclosures can be constructed in a variety of materials and finishes. Standard enclosures are constructed using steel sheet with rating conforming to IP55. Our standard enclosure is coated with a metallic zinc flame spray, epoxy seal coat, polyurethane top coat in colour RAL 7036 gloss. However, almost any specification of material, coating or IP rating can be accommodated. Enclosures are fitted with galvanized sunshade for outdoor installations, lifting hooks and earth stud. Transformer Rectifiers are suitable for indoor/outdoor plinth mounting. Smaller units can be post or wall mounted.

Enclosure - Air cooled Transformer Rectifier enclosure comprises of single housing which accommodates a.c. and d.c. terminals, instruments and breaker.

Operation - Tap set Transformer Rectifiers convert utility supply to the required d.c. output in the following stages:

- Voltage is stepped down using multi tap isolation transformer.
- Transformer taps are selected using rotary switches or link bars.
- Rectification is achieved using full wave diode bridge assembly.
- DC output voltage filtering (smoothing) is achieved with a choke and capacitor.

Safety/Protection – AC input breaker is provided for over load and short circuit protection. Lightning arrestor is provided on the input side and surge arrestor is provided on the output side. High speed fuses are provided on the transformer secondary.

Instrument panel – The front instrument panel houses rotary switches, circuit breaker, d.c. voltmeter and d.c. ammeter. A voltmeter with reference electrode selector switch can be offered to monitor structure potential.

Control– Constant voltage control is obtainable in 16, 24, 36 or 64 steps using rotary switches.

Output ripple - Ripple is less than 5% of RMS voltage from 10% to 100% of rated output.

Transformer -Transformers are open dry type built to class F insulation with temperature limited to class B.

Efficiency - Transformer efficiency is around 95%. Total efficiency is variable depending on Transformer Rectifier type and features but is usually greater than 80%.

Zone classification - Transformer Rectifiers can be manufactured to hazardous area classification. SIRA certification can also be provided.

Remote Monitoring - Remote monitoring can be offered using 4-20mA output from transducers. Digital monitoring using RS485 network can be offered and requires a master control unit. Alarm signals can be offered using potential free contacts.



Single phase input

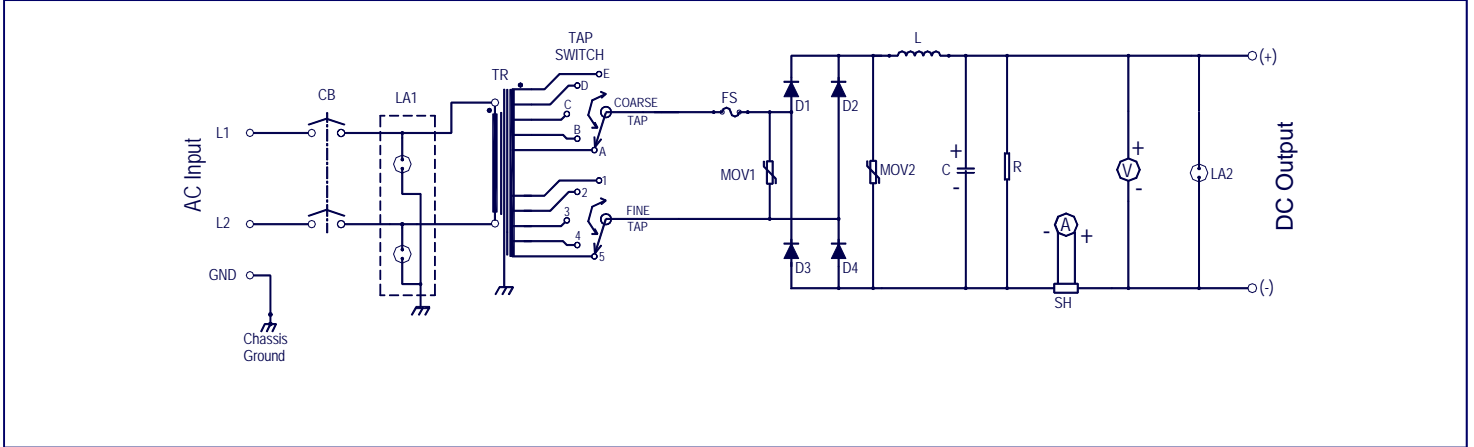

Three phase input

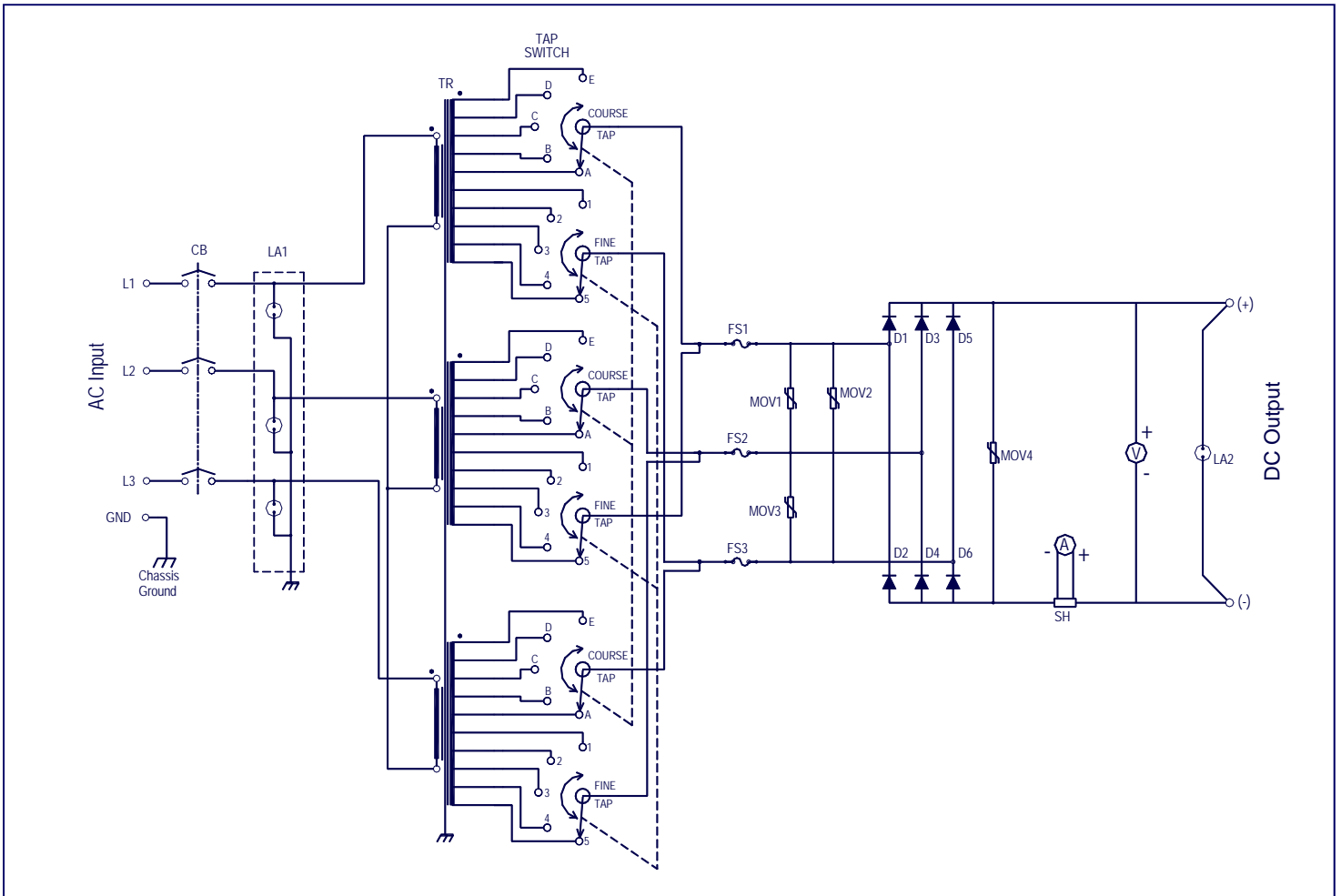

Detailed design and GA drawings will be provided for approval after order is placed